

Funktion-One Research LTD
 Hoyle, Beare Green, Dorking, Surrey, RH5 4PS, UK
 mail@funktion-one.com +44 (0)1306 712820

Sheet: Overview
 Funktion-One Product Detail Drawing

A3 Sheet Scale: 1:6
 Filename:

Drawn By: Mike Igglesden 22/05/2023
 Evo6EH-F1-DD=T0021-01

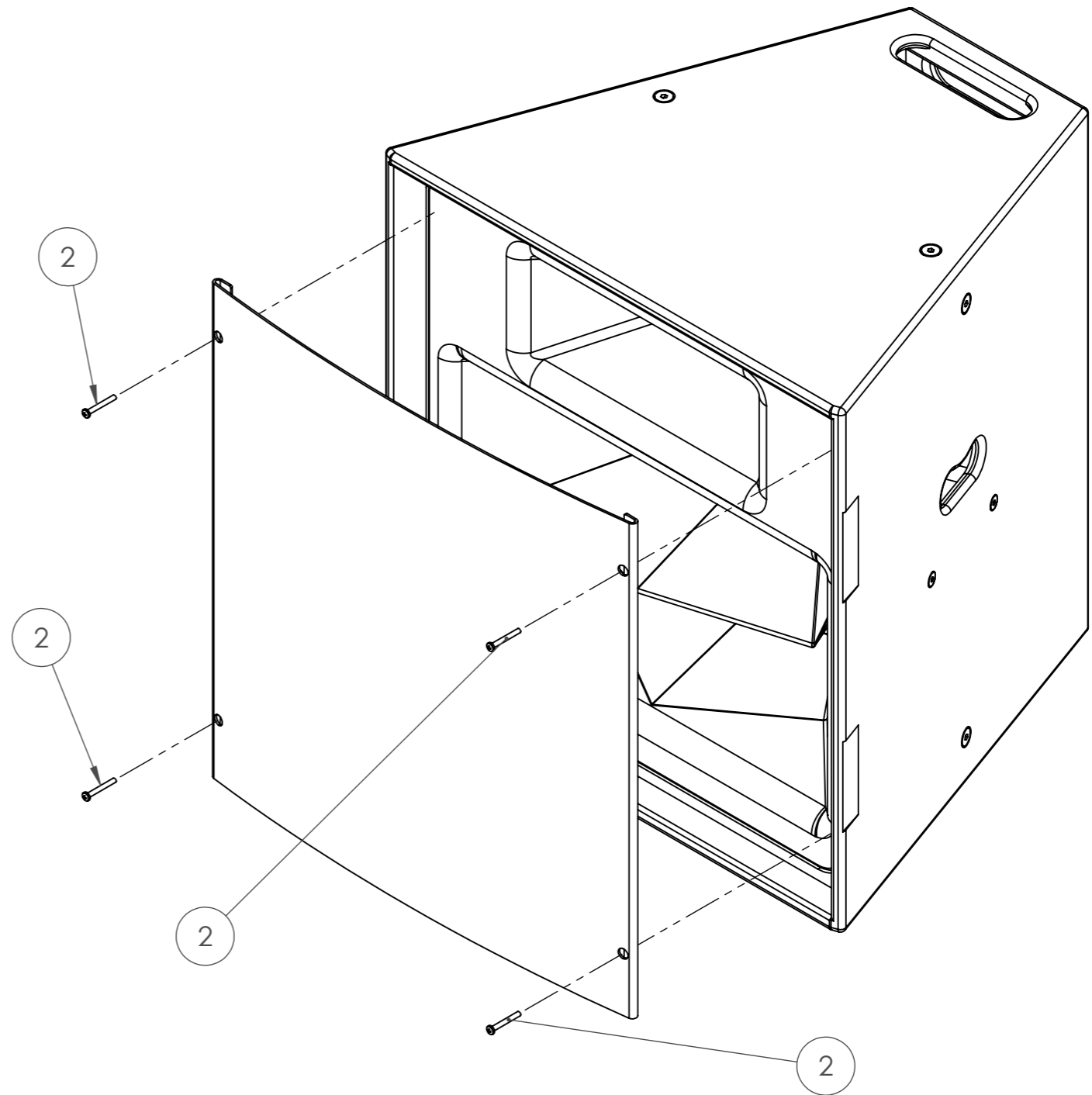
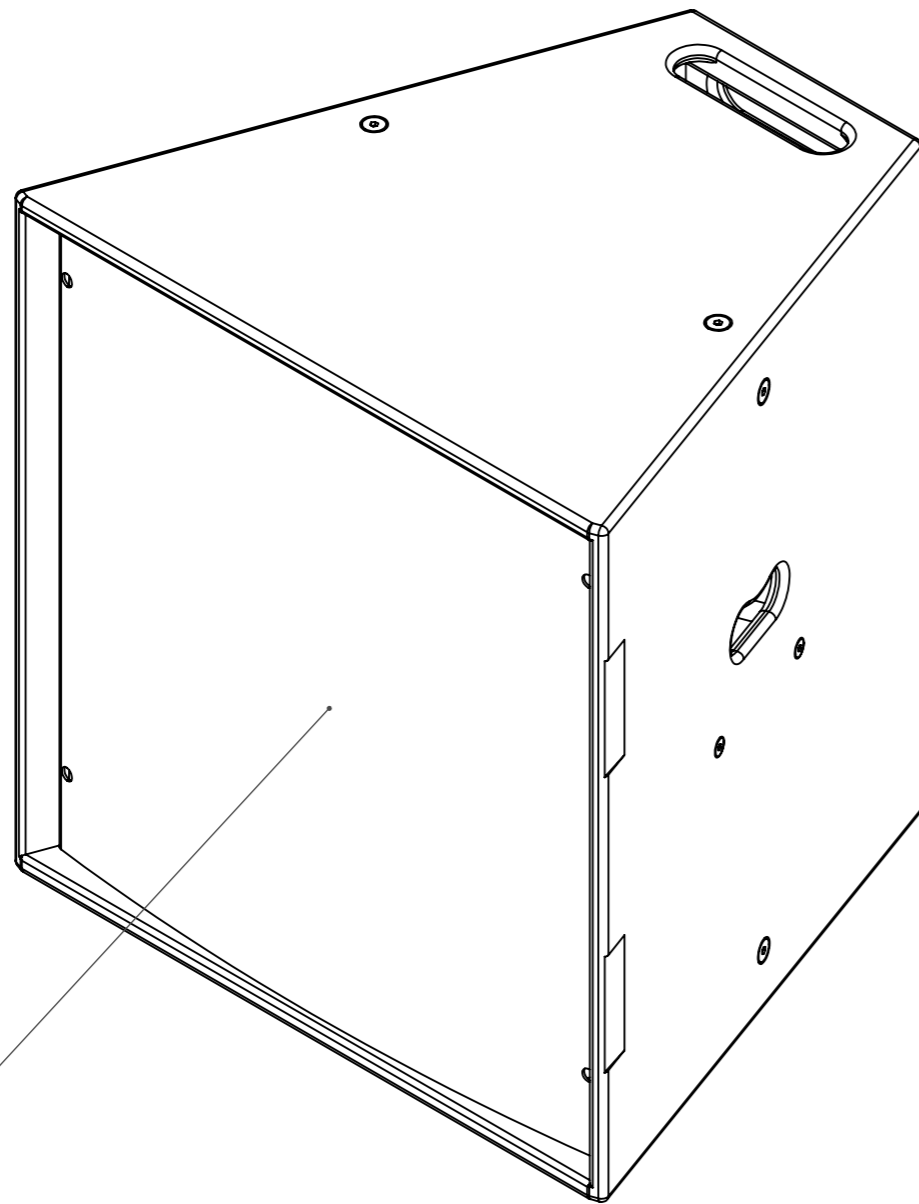

Evo 6EH ordered with grille fitted.
Hex punched 2mm steel, black powder coat and
foam backed for descreet aesthetic.

Removed and reattachment of grille with 4 x M5 x
40mm pozi (PZ2) pan head bolts. These bolts are used
to also secure the wave guide to the cabinet and
should always be fitted with or without the grille.

ITEM	DESCRIPTION	QUANTITY
1	EVO6E GRILLE, HEX PUNCHED, FOAM BACKED	1
2	M5 X 40mm POZI PAN HEAD BOLT	4

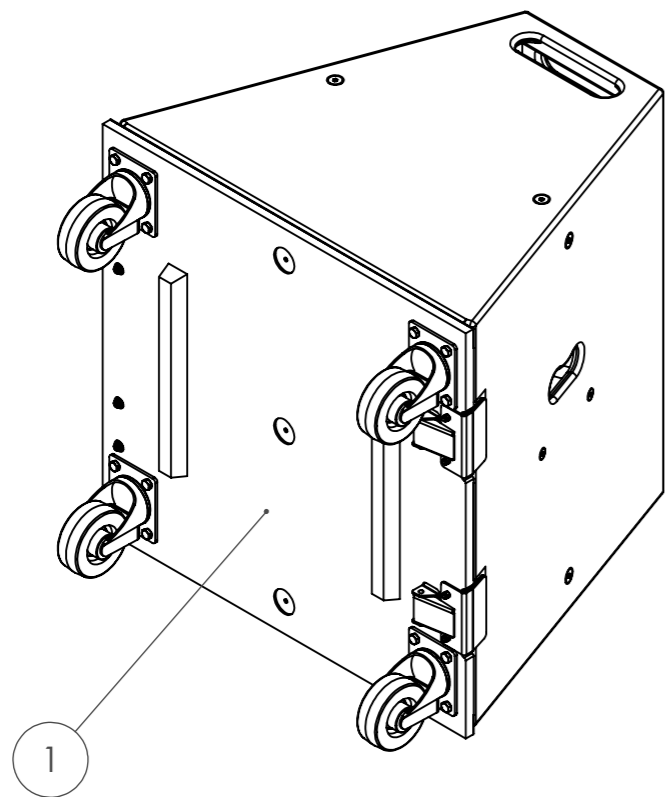

Evo6EH with wheel board fitted.

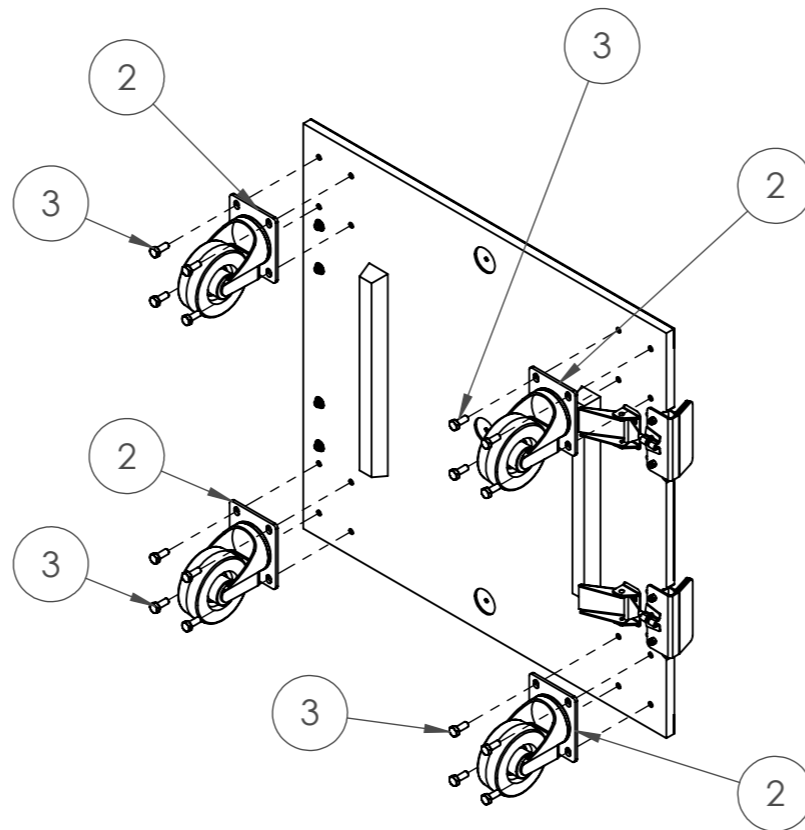

Evo6EH packed with wheel board, but without wheels fitted. Each wheel requires 4 x M8 x 20mm hex bolts (17mm) (supplied). We suggest using a contact adhesive on the bolt thread to secure bolts.

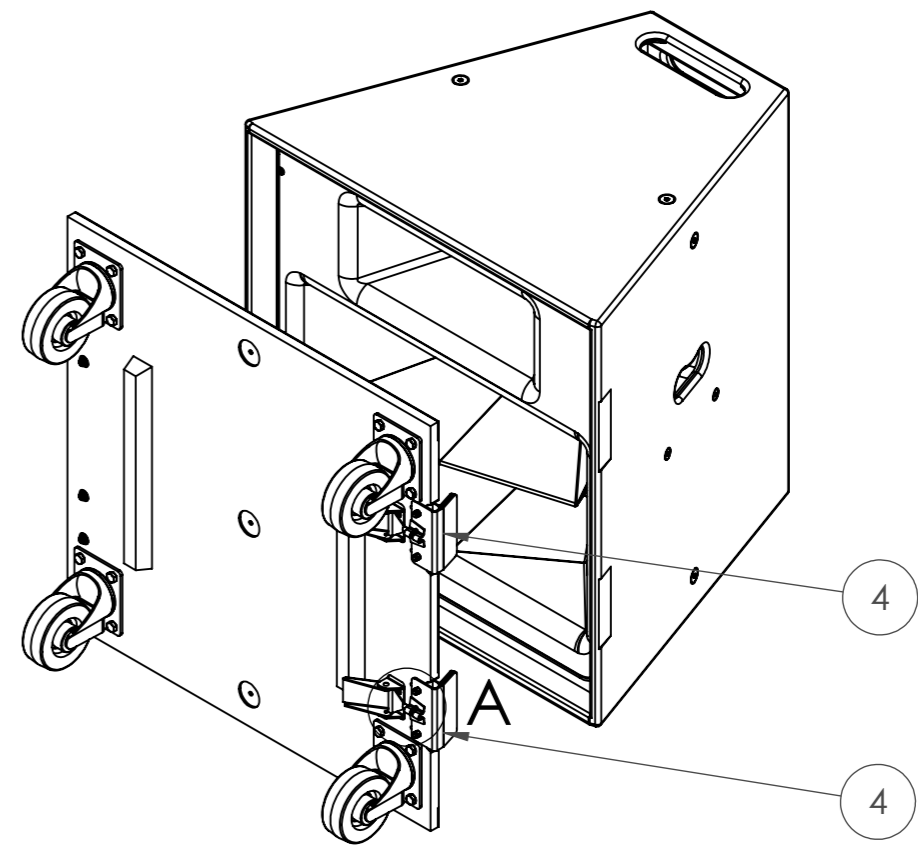

The two over centre latches clamp onto the Evo6EH cabinet in their side recesses. To fit wheel board, sit the cabinet on its bottom face as above, hook onto the cabinet on the fixed clamp side first, then, with the over centrlatches open, swing the board onto the front face and close the latches. Should the latches become loose, tighten the M10 (13mm) nut.

ITEM	DESCRIPTION	QUANTITY
1	WB6/7 EVOLUTION 6 & 7 EH WHEEL BOARD	1
2	4" CASTOR WHEEL	4
3	M8 X 20mm HEX BOLT	16
4	OVER CENTR LATCH	2

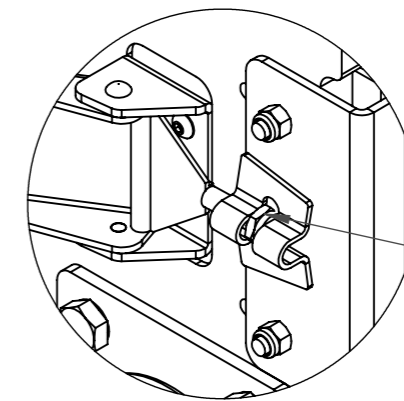

DETAIL A

SCALE 1 : 2

Adjustment nut