

BFP - Butterfly Plate

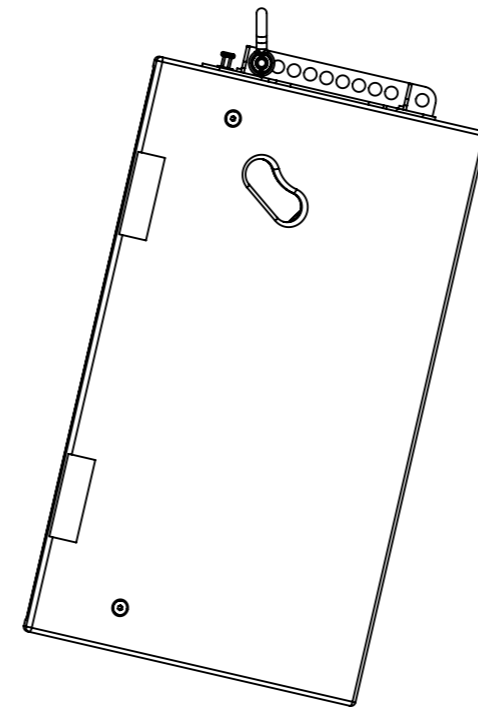
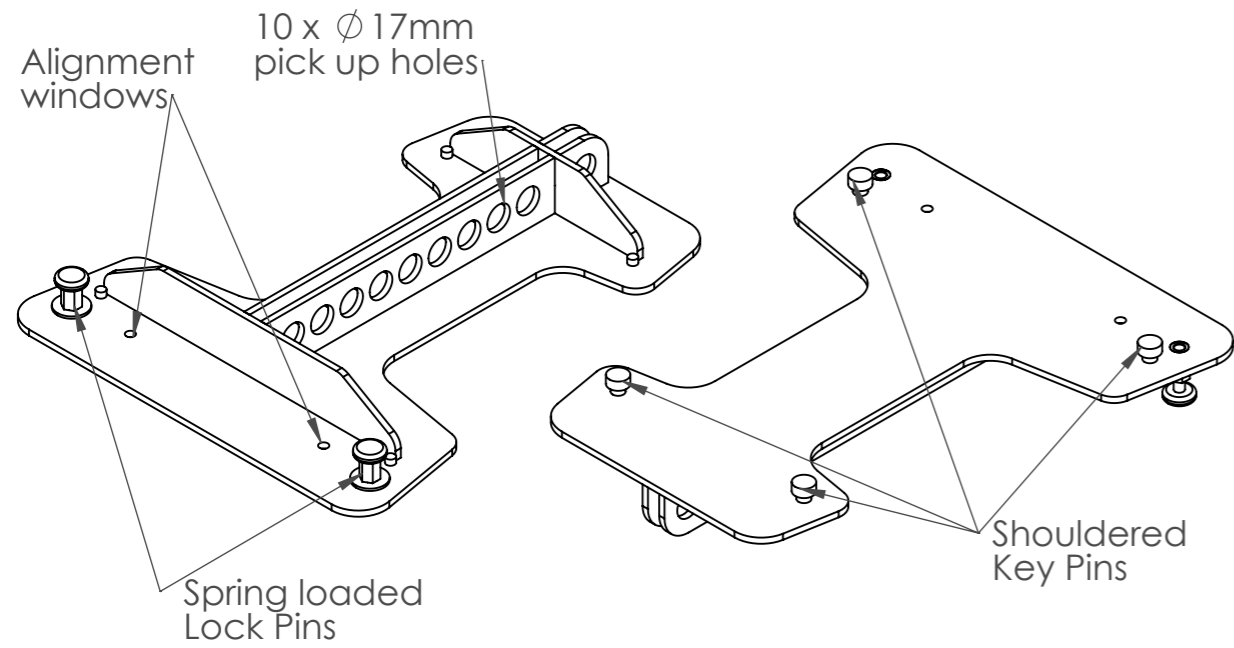

To be used with a 2 Ton Bow shackle.

The Evo 2 can be used in either vertical orientation.

The Butterfly Plate enables ten choices of angle from +13 to -16°.

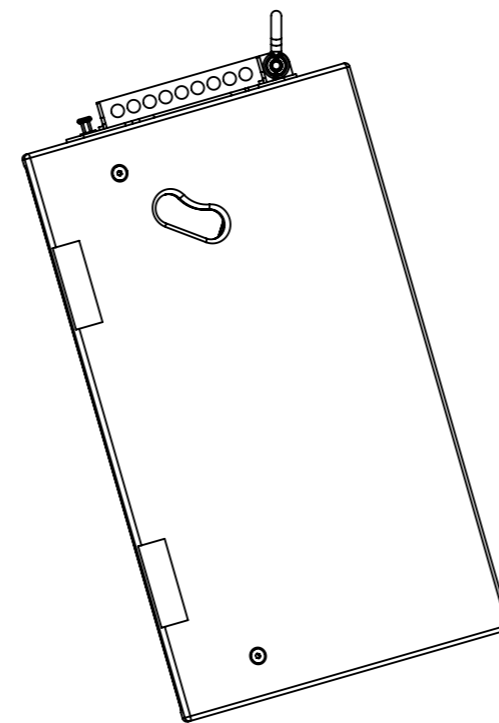
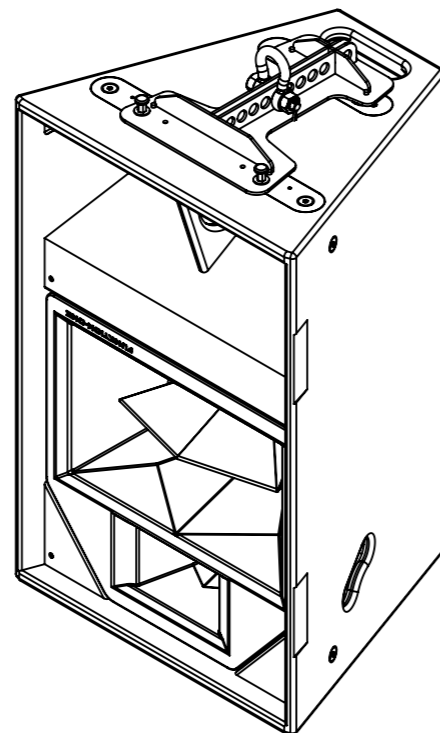
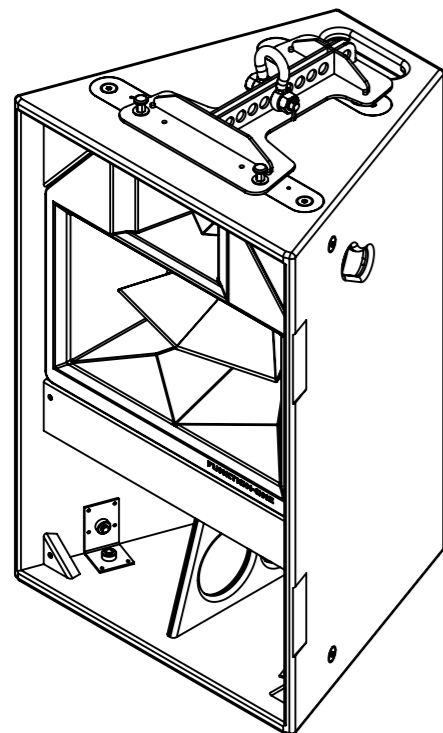

To fit a BFP to an Evo 2 loudspeaker.

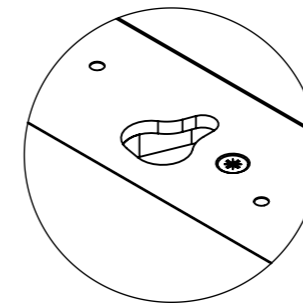

Alignment markings

Keyholes

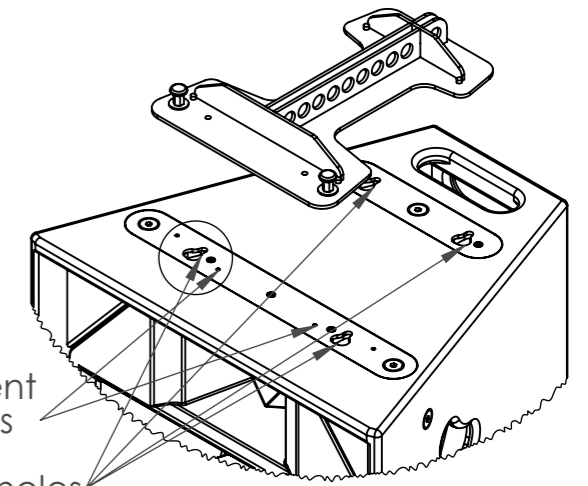

1. Align Key Pins with Key Holes. BFP will drop into Key Holes and sit flat on loudspeaker. Lock pins will be pushed up.

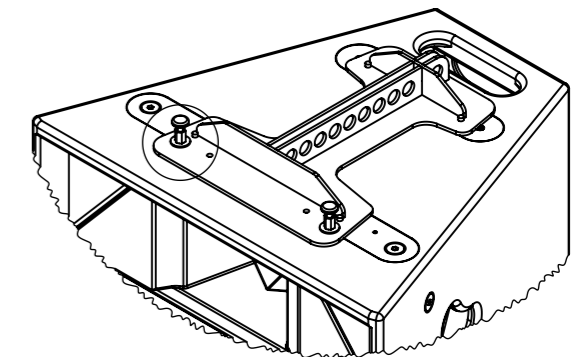
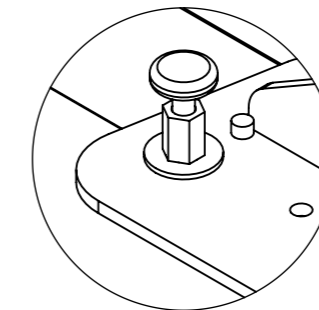

2. Slide BFP towards back of the loudspeaker to engage the shoulders of the Key Pins. The Lock Pins will spring down.

3. Before lifting, check the Lock Pins are fully engaged (down), the BFP is flat and secure to the loudspeaker and the yellow alignment markings are centred in the alignment windows.

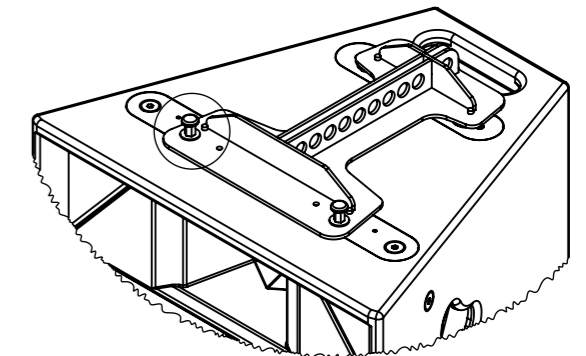
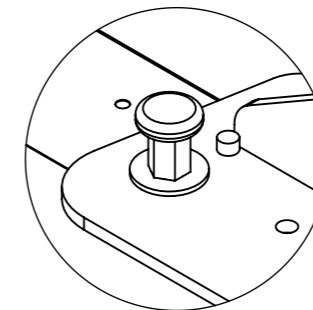

4. Once in position, secure Evo 2 with a safety wire around handle or on to M10 flypoint on the side of the Evo 2.

To remove, lift Lock Pin button, allowing the BFP to slide forward and disengage Key Bolts.

Funktion-One Research LTD
Hoyle, Beare Green, Dorking, Surrey, RH5 4PS, UK
mail@funktion-one.com +44 (0)1306 712820

Sheet: BFP on Evo2 Detail Drawing

Funktion-One Accessory Drawing

A3 Sheet Scale: 1:4

Filename:

Drawn By: Mike Igglesden

25/06/2024

BFP-E2-F1-AD=T0252-01

BFP - Butterfly Plate

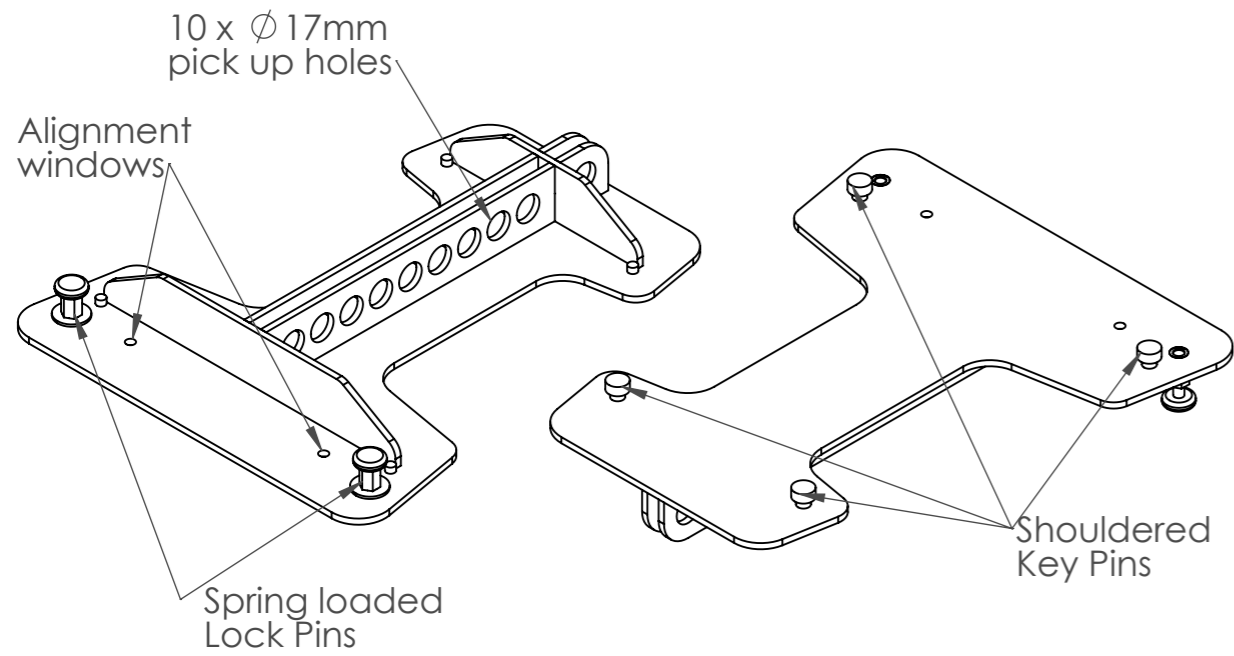

To be used with a 2 Ton Bow Shackle.

The Butterfly Plate enables ten choices of angle from +10 to -13°.

The Evo 2 can be used in either vertical orientation.

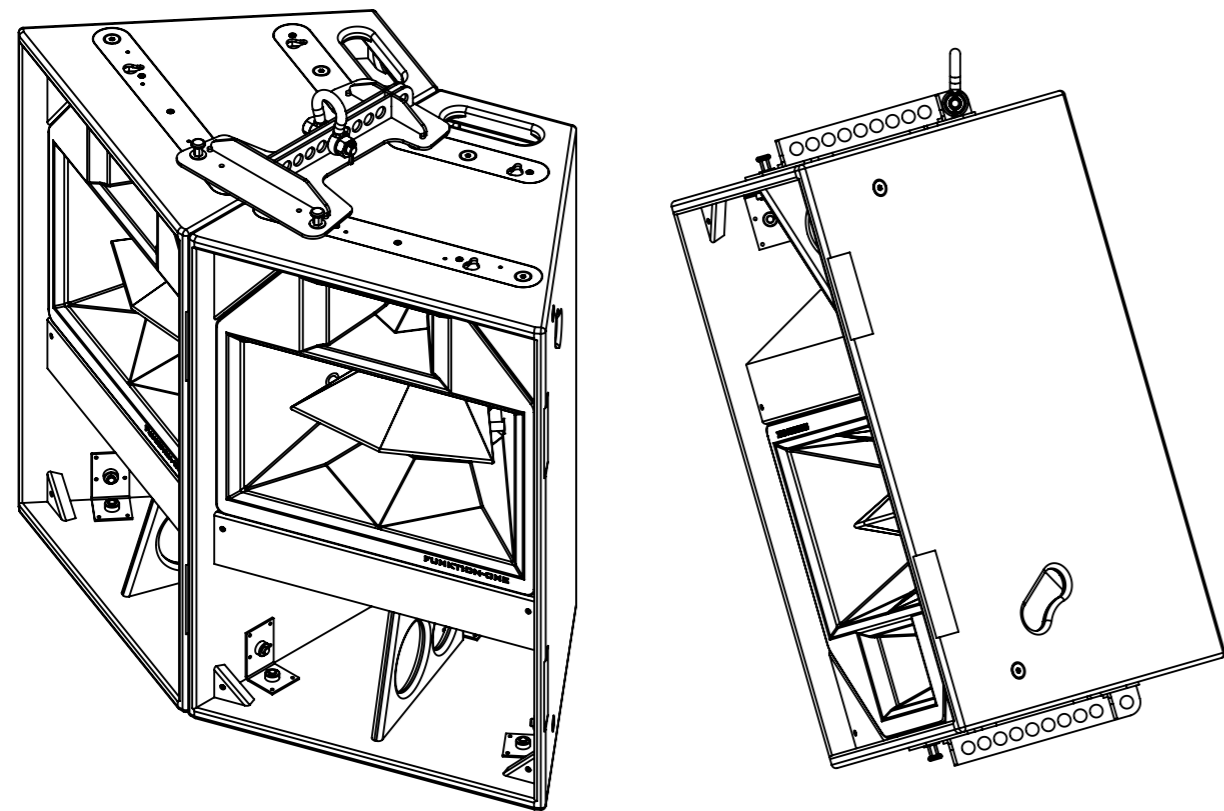

To fit a pair of BFPs to a pair of Evo 2 loudspeakers.

1. Position two Evo 2 loudspeaker together on a flat surface.

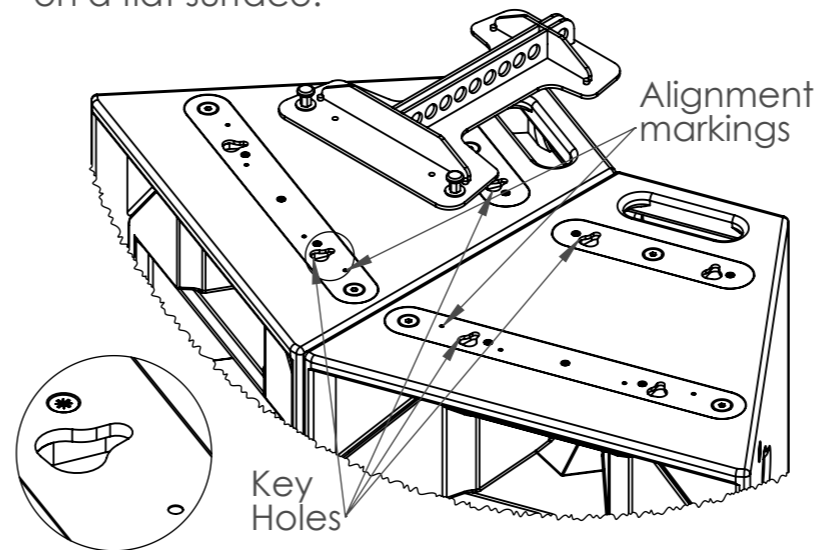

2. Align key pins with the central Key Holes. BFP will drop into Key Holes and sit flat on the loudspeaker. Lock Pins will be pushed up.

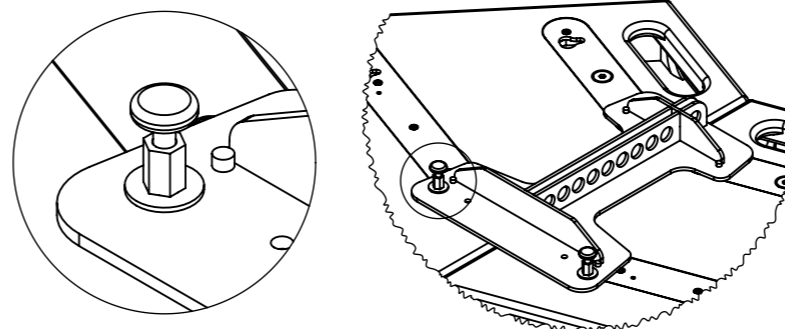

3. Slide BFP towards back of loudspeakers to engage the shoulders of the Key Pins. The Lock Pins will spring down.

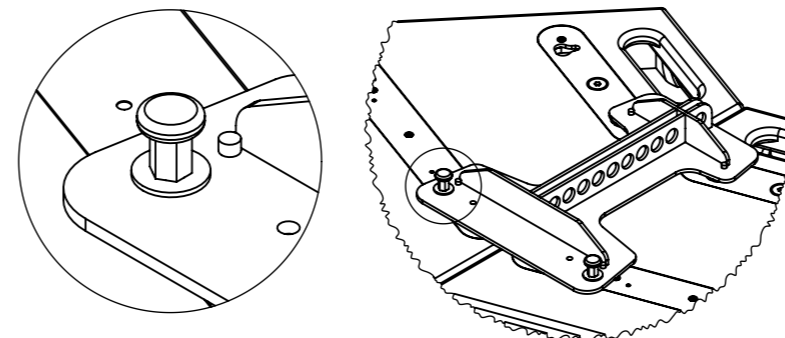

4. Before lifting, check the Lock Pins are fully engaged (down), the BFP is flat and secure to the loudspeaker and the yellow alignment markings are centred in the alignment windows.

5. When arraying two Evo 2, a second BFP must be secured to the underside to lock the two loudspeakers together. Carefully lift the array with the single BFP to allow access to the underside of the array.

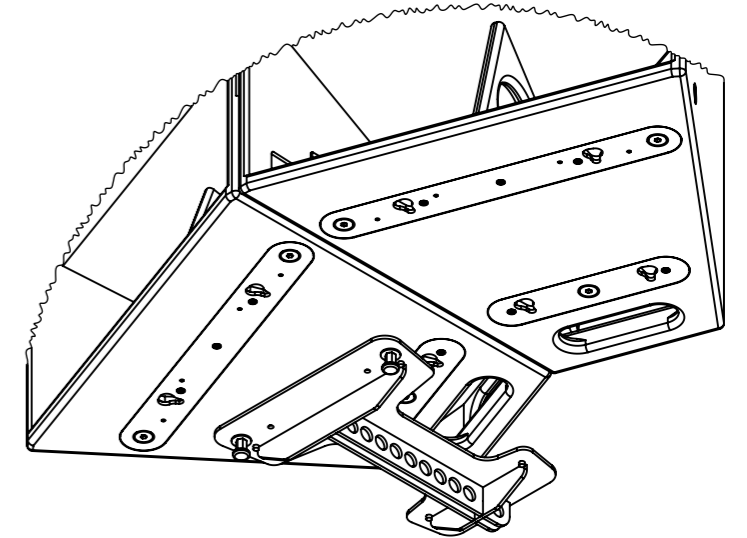

6. Repeat steps 2, 3 & 4 with the BFP on the underside.

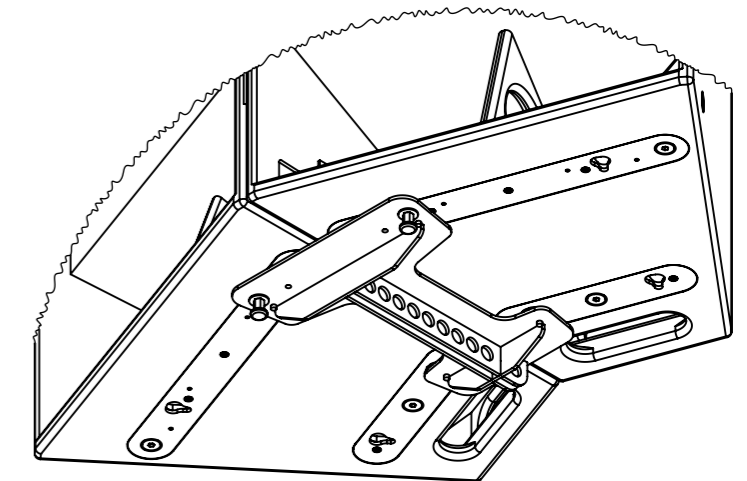

7. Once in position, secure loudspeakers with a safety wire around handle or into M10 flypoint on the side of the Evo 2. The underside BFP should also have a safety attached,

To remove, lift Lock Pin button, allowing the BFP to slide forward and disengage Key Pins.

Funktion-One Research LTD
Hoyle, Beare Green, Dorking, Surrey, RH5 4PS, UK
mail@funktion-one.com +44 (0)1306 712820

Sheet: 2 BFP on 2 Evo2 Detail Drawing

Funktion-One Accessory Drawing

A3 Sheet Scale: 1:4

Filename:

Drawn By: Mike Igglesden

25/06/2024

BFP-E2-F1-AD=T0252-01

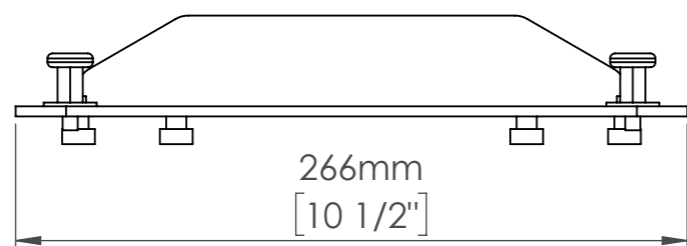
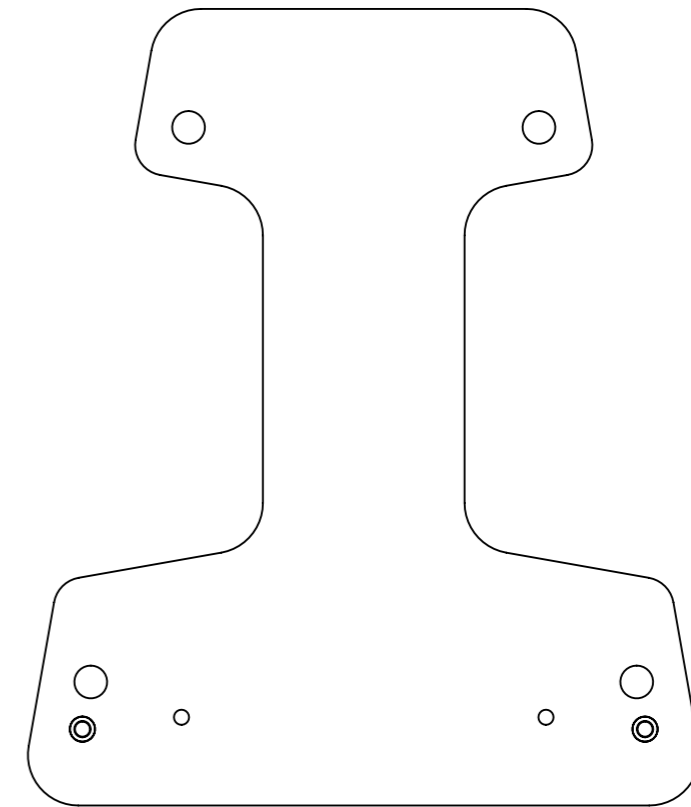
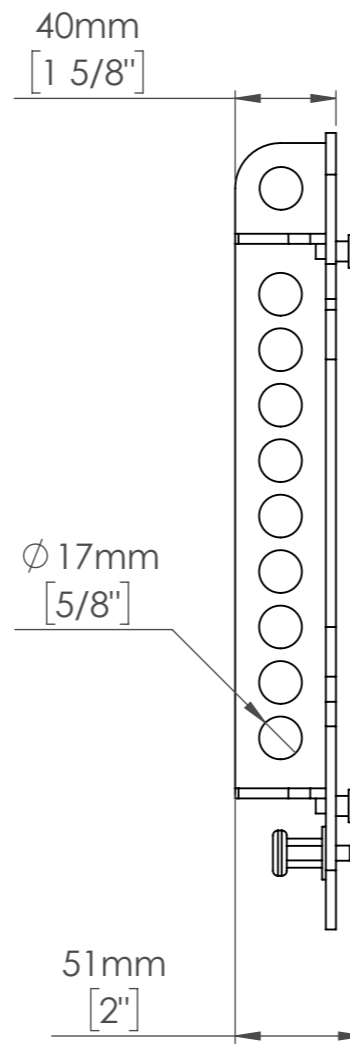
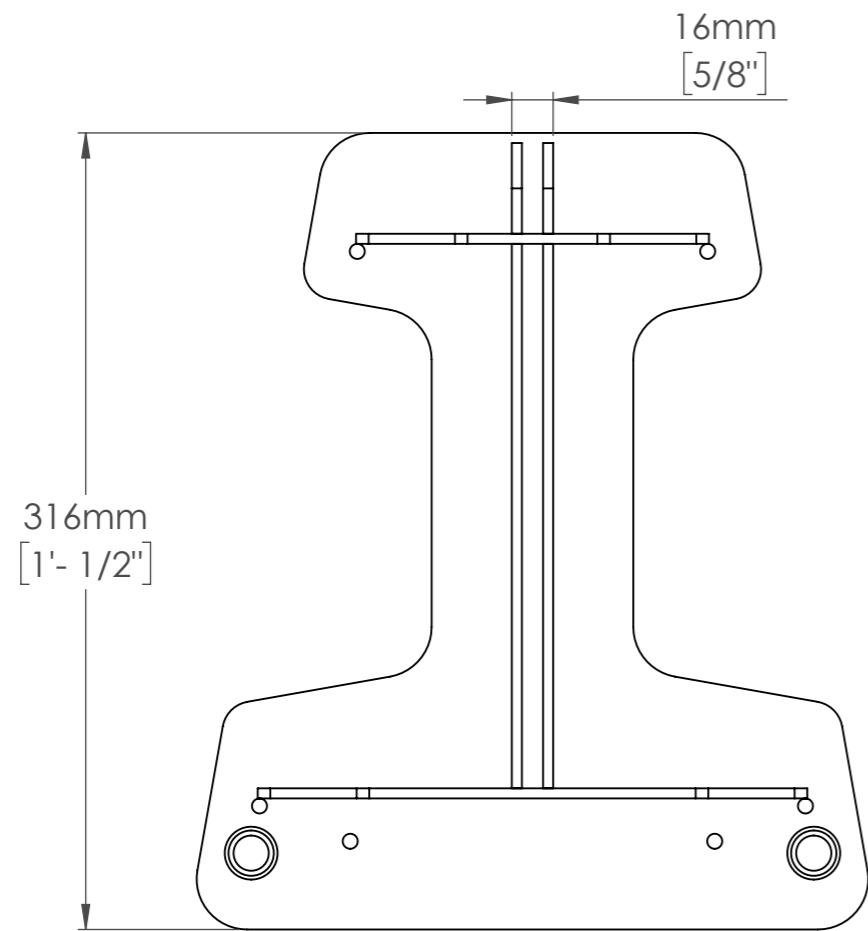

Funktion-One Research LTD
 Hoyle, Beare Green, Dorking, Surrey, RH5 4PS, UK
 mail@funktion-one.com +44 (0)1306 712820

Sheet: Technical Drawing

Funktion-One Accessory Drawing

A3 Sheet Scale: 1:3

Filename:

Drawn By: Mike Igglesden

25/06/2024

BFP-E2-F1-AD=T0252-01