

Evo2 with wheel board fitted.

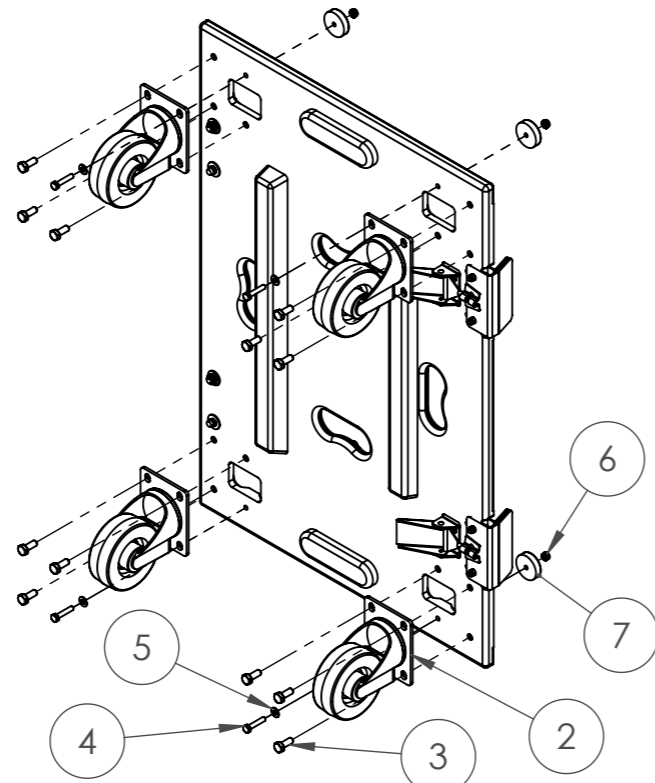

Wheel board packed without wheels fitted. Each wheel requires 3 x M8 x 20mm hex bolts (13mm). We suggest using a contact adhesive on the bolt thread to secure bolts. The M6 x 30mm bolt, washer, nylock nut and locator puck to be refitted with wheel.

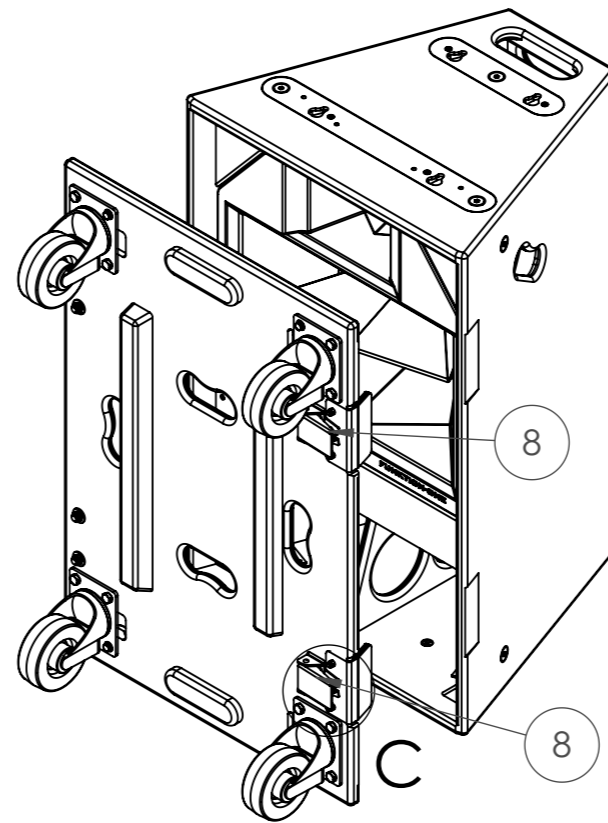

The two over centre latches clamp onto the Evo 2 cabinet in their side recesses. To fit wheel board, sit the cabinet on its bottom face as above, hook onto the cabinet on the fixed clamp side first, then, with the over centre latches open, swing the board onto the front face and close the latches. Should the latches become loose, tighten the M6 (10mm) nut.

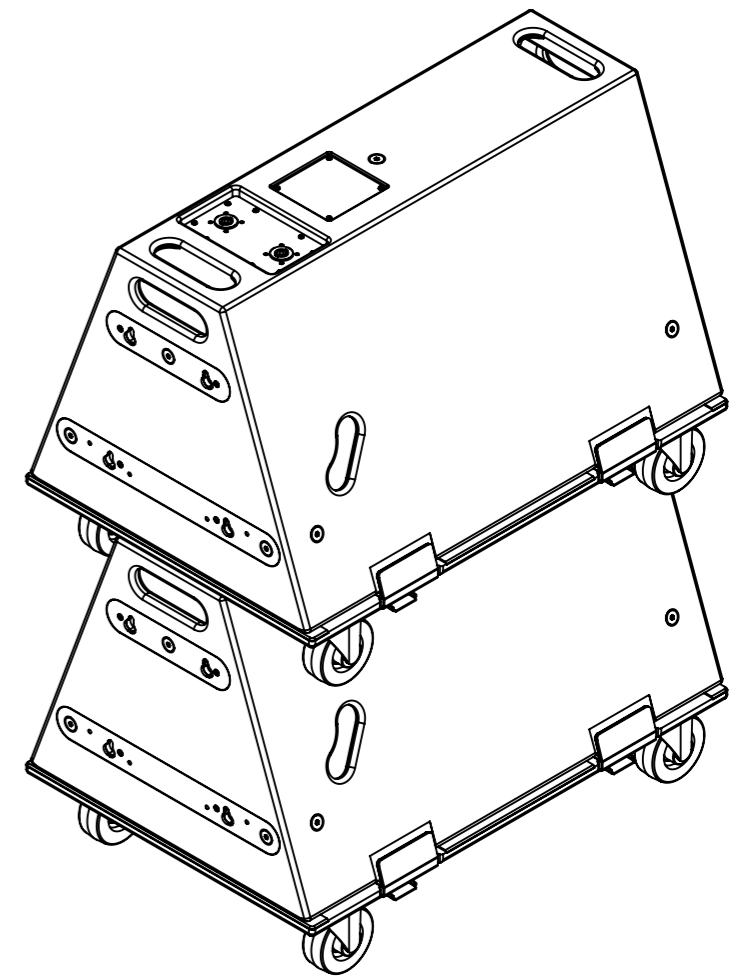

Wheel boards stack with and without loudspeakers for ease of transportation and storage.

ITEM	DESCRIPTION	QUANTITY
1	EVOLUTION 2 WHEEL BOARD	1
2	4" CASTOR WHEEL	4
3	M8 X 20mm HEX BOLT	12
4	M6 X 30mm HEX BOLT*	4
5	M6 WASHER*	4
6	M6 NYLOCK BOLT*	4
7	LOCATOR PUCK*	4
8	OVER CENTR LATCH*	2

* fitted to wheel board in packaging.

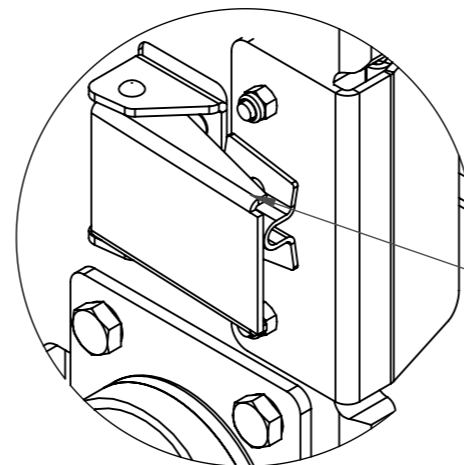

DETAIL C

SCALE 1 : 2

Adjustment nut

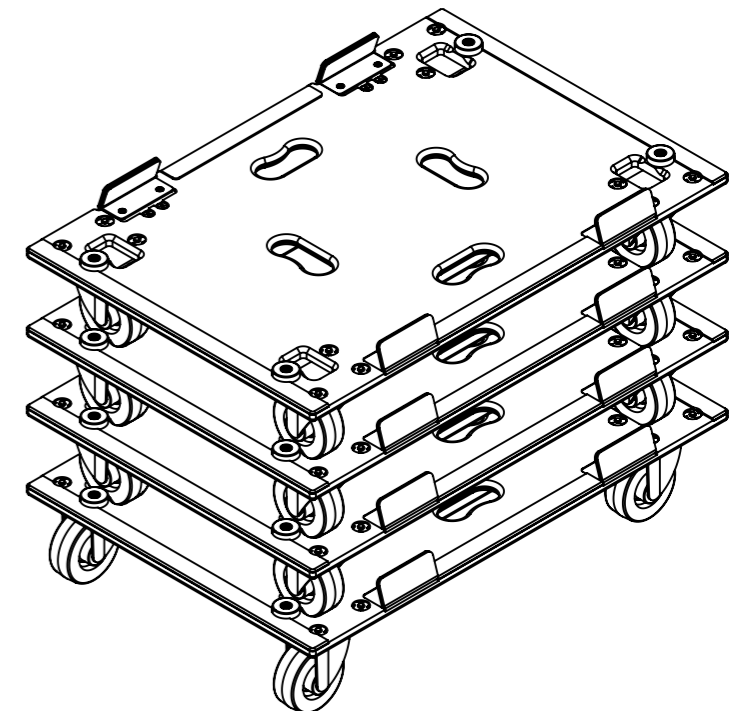

Funktion-One Research LTD
 Hoyle, Beare Green, Dorking, Surrey, RH5 4PS, UK
 mail@funktion-one.com +44 (0)1306 712820

Sheet:Detail Drawing

Funktion-One Accessory Drawing

A3 Sheet Scale: 1:10

Filename:

Drawn By: Mike Igglesden

25/06/2024

WB-E2-F1-AD=T0276-00

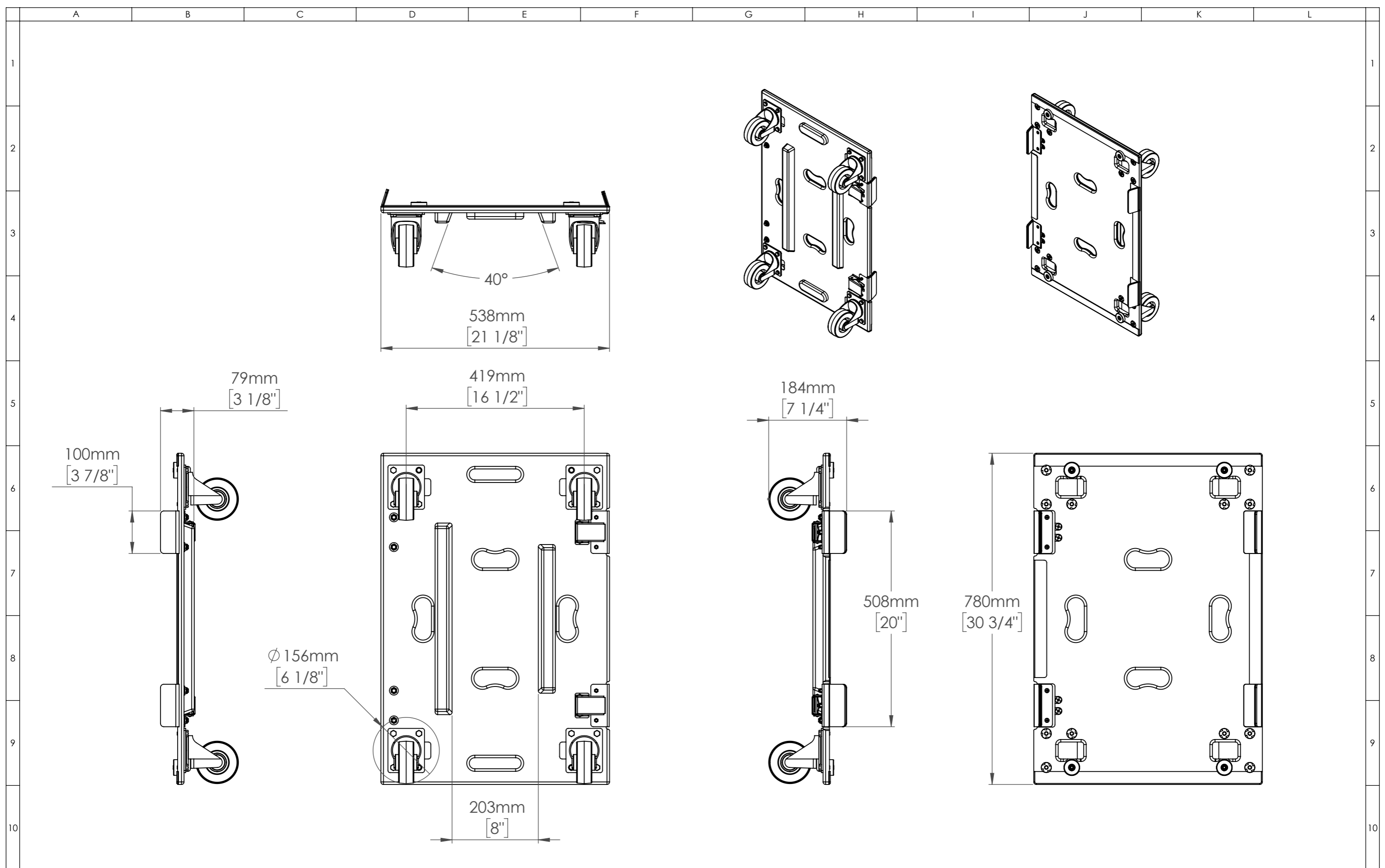

Funktion-One Research LTD
 Hoyle, Beare Green, Dorking, Surrey, RH5 4PS, UK
 mail@funktion-one.com +44 (0)1306 712820

Sheet: Technical Drawing
 Funktion-One Accessory Drawing

A3 Sheet Scale: 1:8
 Filename:

Drawn By: Mike Igglesden 25/06/2024
WB-E2-F1-AD=T0276-00

